

For Installation of Augusta 4 bollard. Model. AUG-10001 and AUG-10002

Product drawing (dimensions)
CE IP65 IK08 CLASS I

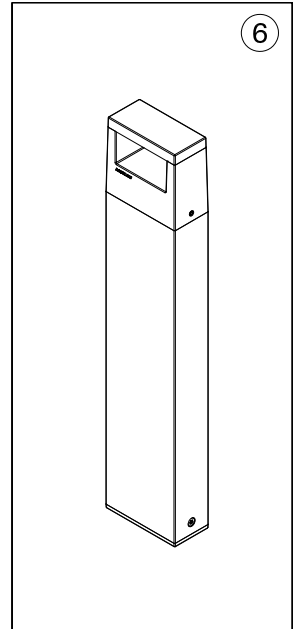
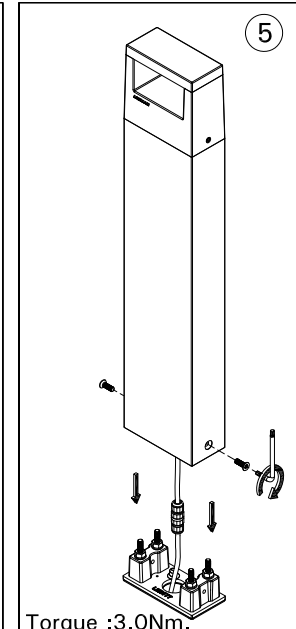
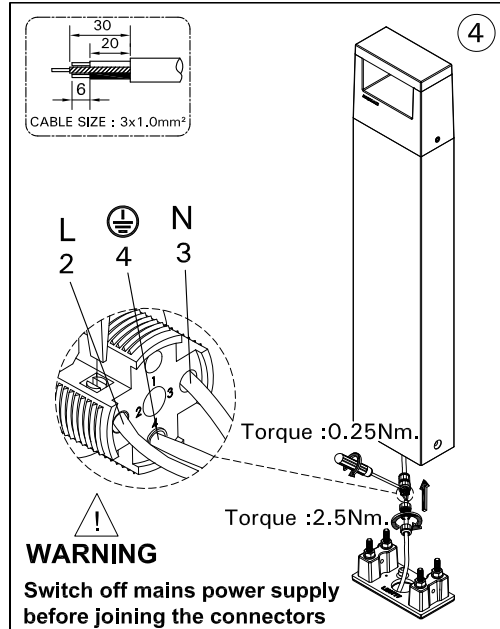
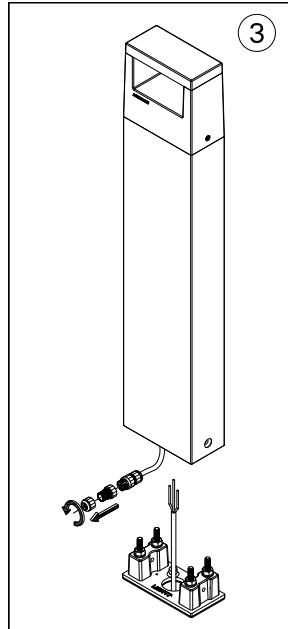
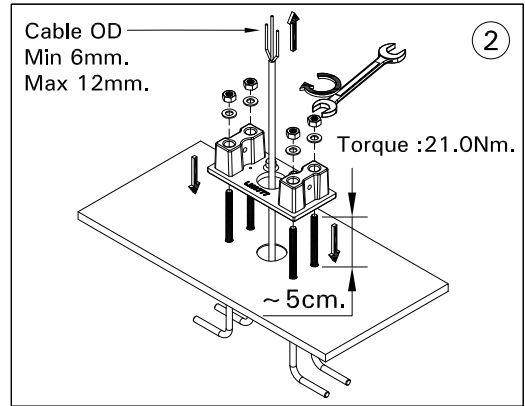
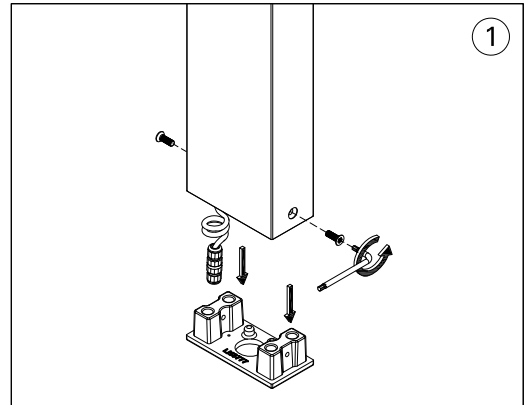
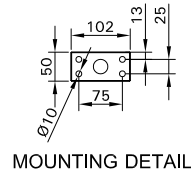
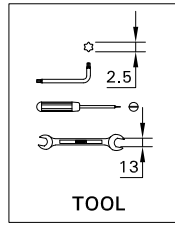
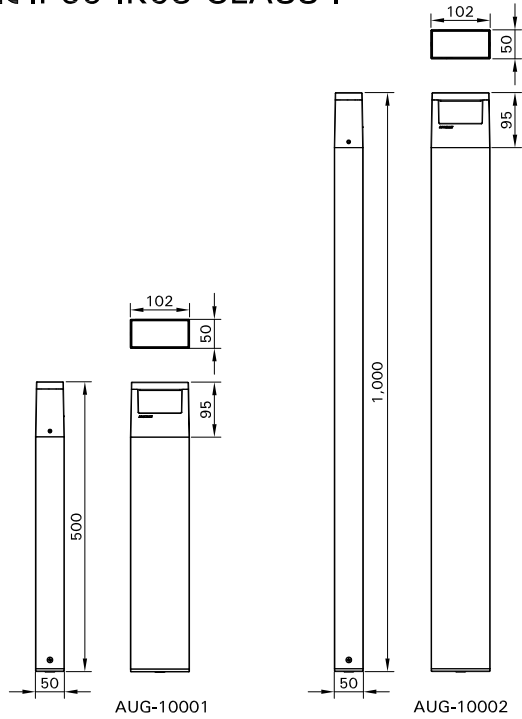

- LIGMAN standard products are supplied with the control gear 220-240V 50/60Hz. The control gear for other voltages and frequencies is available upon request, please consult us for more details.
- LIGMAN luminaires are designed to conform IEC 60598 2-1 standard.

Technical amendments and modifications techniques reserved.

Ligman Lighting

Europe Headquarters
Ligman Europe s.r.o.
VGP Park Usti nad Labem, P 2
Prestanov 113
403 17 Prestanov
Czech Republic
Tel. +420 608 740 504 | sales.cz@ligman.com

Thailand Headquarters
Ligman Lighting Co., Ltd.
17/2 Moo 4, Monthong, Bangnampreaw
Chachoengsao 24150 Thailand
Tel : +66 (2) 7339140
info@ligman.com

Ligman SAS France
7 rue Antoine Becquerel
Centre d'activités Triasis
31140, Launaguet
Tel: +33 5 61 70 24 62
sales.fr@ligman.com